

PreSet[®] Hub and Rotor



PreSet Technology for Air Disc Brakes.

CON  **MET**[®]
Pointing the Way™



PreSet[®] Hub and Rotor

Lightweight / Low Maintenance Solutions for Air Disc Brakes

ConMet's engineers went back to the drawing board for this one. We've managed to put our patented PreSet technology together with industry-leading brake rotors for a simple one-piece installation.

ConMet worked closely with air disc brake manufacturers to develop PreSet wheel hubs to fit their most popular brake rotors.

This joint development effort has resulted in the most reliable, cost effective hub and rotor combinations in the industry, complementing the advantages offered by today's air disc brake technology.

PreSet Hub and Rotor combinations are available in both ductile iron and lightweight aluminum, and in a variety of configurations for various axle types. Contact us for details on which product would best suit your specific application.

To find out more about our full line of wheel-end components, call **1-800-547-9473** or visit us online at www.conmet.com.

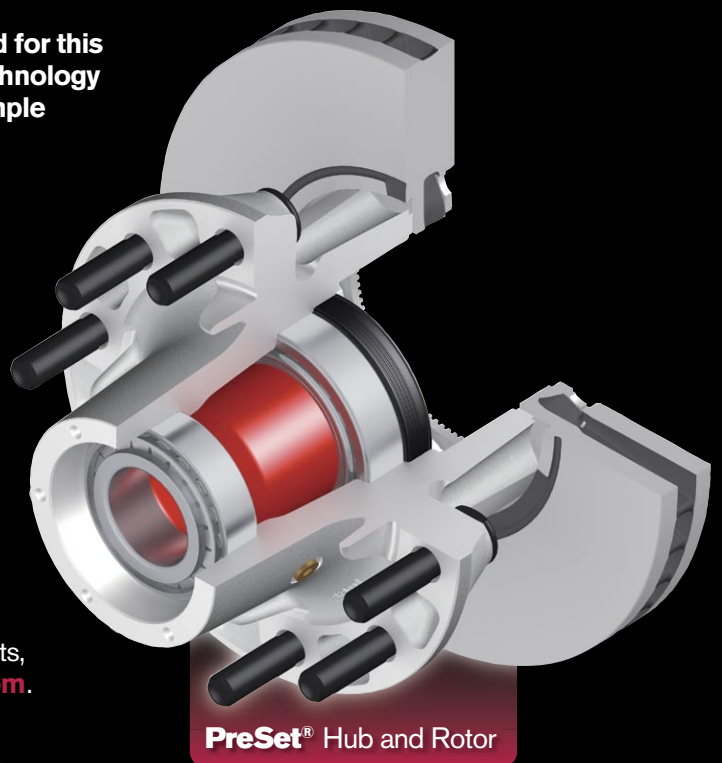

CON
MET[®]

Pointing the Way[™]