

Technology Bulletin

A Field Service Publication of Consolidated Metco, Inc.

#10025782 Rev E July 15, 2011 Page 1

PreSet® Hubcaps Available for Hubs Lubricated with Oil, Grade 2 Grease and Semi-Fluid Grease

Consolidated Metco offers a family of hubcaps that are used in conjunction with both oil lubricated and grease lubricated PreSet® trailer hubs. The hubcaps are used for easy identification of ConMet PreSet hubs.

Oil Lubricated PreSet® Hubcap:

The hubcaps for oil lubricated PreSet® hubs come in both the 5.50" bolt circle for the SAE "N" type trailer axle and also the 6.75" bolt circle for the SAE "P" type trailer axle. Oil lubricated hubcaps are identified by the rubber plug insert, clear sight window, and part number. The part numbers are as follows:

| Axle | ConMet® Part Number |
|------|---------------------|
| "N" | 106819 |
| "P" | 106870 |

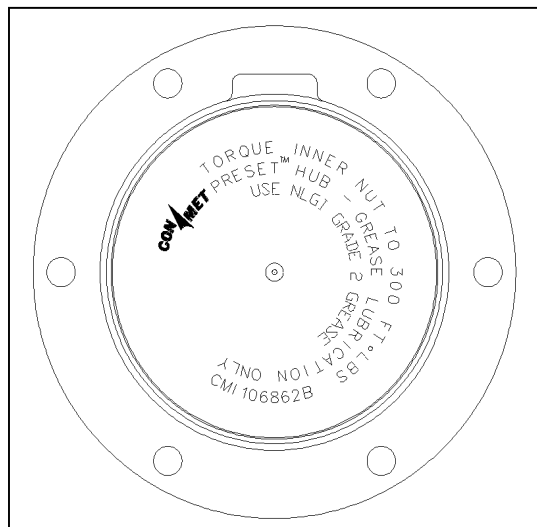
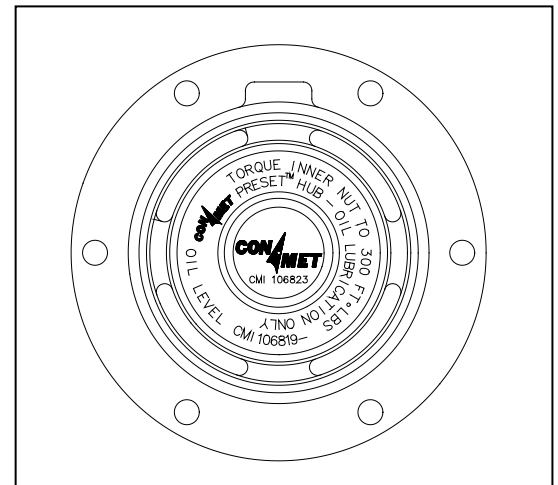

Grade 2 Grease Lubricated PreSet® Hubcap

The hubcaps for Grade 2 grease lubricated PreSet® hubs come in both the 5.50" bolt circle for the SAE "N" type trailer axle and also the 6.75" bolt circle for the SAE "P" type trailer axle. Grade 2 grease lubricated hubcaps are identified by the plain front with no sight window, no vent, and the part number. The part numbers are as follows:

| Axle | ConMet® Part Number |
|------|---------------------|
| "N" | 106862 |
| "P" | 106866 |

(Continued on page 2)

THIS INFORMATION IS INTENDED AS A REFERENCE SOURCE ONLY. CONSOLIDATED METCO DOES NOT ASSUME ANY LIABILITY IN THE EVENT OF IMPROPER USE OR MIS-MATCH OF COMPONENTS. FOR ADDITIONAL INFORMATION, SEE CONMET ALUMINUM HUB INSTALLATION AND SERVICE GUIDELINES, VISIT OUR WEB SITE AT WWW.CONMET.COM, OR CALL (800) 425-4827.

Technology Bulletin

A Field Service Publication of Consolidated Metco, Inc.

#10025782 Rev E July 15, 2011 Page 2

ConMet Family of PreSet® Hubcaps (Continued)

Semi-fluid Grease Lubricated PreSet® Hubcap:

The hubcaps for semi-fluid grease lubricated PreSet® hubs come in both the 5.5" bolt circle for SAE "N" type trailer axle and also the 6.75" bolt circle for the SAE "P" type trailer axle. Semi-fluid grease lubricated hubcaps are identified by "Semi-fluid Grease Only" lettering on the plain front and the part number. The part numbers are as follows:

| Axle | ConMet® Part Number |
|------|---------------------|
| "N" | 10018622 |
| "P" | 10018621 |

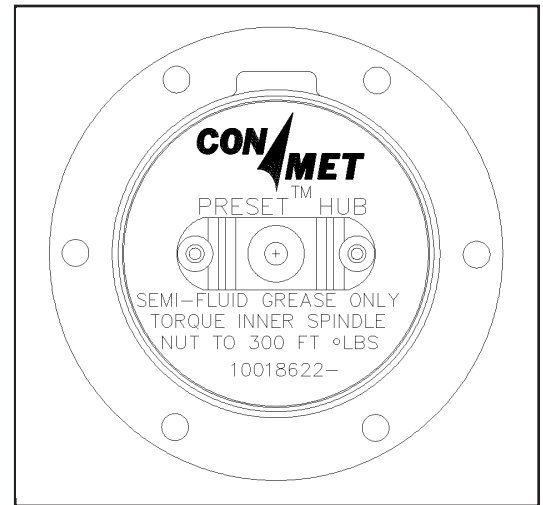

ConMet® Hubcap Installation Instructions

1. Both the hubcap and hub gasket surface should be clean from dirt and oil before installation.
2. Make sure that there are no burrs or sharp edges before installation.
3. Once the cap and gasket are retained to the hub by all the bolts, apply torque in a star pattern to 12-18 ft*lb.
4. The breathing vent must be clean and free of debris. Any blockage of the breathing vent will cause venting failure and void the warranty.

THIS INFORMATION IS INTENDED AS A REFERENCE SOURCE ONLY. CONSOLIDATED METCO DOES NOT ASSUME ANY LIABILITY IN THE EVENT OF IMPROPER USE OR MIS-MATCH OF COMPONENTS. FOR ADDITIONAL INFORMATION, SEE CONMET ALUMINUM HUB INSTALLATION AND SERVICE GUIDELINES, VISIT OUR WEB SITE AT WWW.CONMET.COM, OR CALL (800) 425-4827.